

general features allgemeine eigenschaften

Tracked undercarriage for overcoming obstacles

Tracked undercarriage with hydrostatic transmission and oscillating rollers in the center of the track.

The patented layout of the rubber track provides a wide area and a low ground pressure, high stability and an excellent driving comfort in all conditions of use.

Water-cooled Diesel engine with electric start.

Petrol engine air cooled available for TC100.

Hydrostatic transmission

With piston pumps with variable displacement and orbital motors (with integrated second speed for TC120d and TC130d).

Steering by the rotation of the tracks.

Pilot assisted travelling controls and lever for safety parking brake (block of the hydraulic) for TC120d and TC130d.

The self-loading shovel

Capacity max di 65 lit (option not available for TC130d).

Hydraulic power take off (P.T.O.)

Double-effect optional with max delivery:

- 25 lt/min at 255 bar pressure for TC100, TC100d and TC120d

- 21 lt/min at 210 bar pressure for TC130d

Other flows/pressures are also available on specific demand.

Tracked undercarriage suitable

for different specific applications.

Raupentransporter mit hydrostatischem Fahrtrieb.

und mittig angebrachten Gelenkrollenlager für eine optimale Fahrwerksauslegung.

Höchste Stabilität und bester Fahrkomfort

durch breite Ausstandsfläche der Raupenketten. Dies gewährleistet ebenfalls eine geringe Bodenbelastung.

Wassergekühlter Dieselmotor mit Elektrostarter.

TC100 verfügbar mit Benzinmotor und luftgekühlt.

Vollhydrostatischer Fahrtrieb durch

variable Kolbenpumpen und Fahrmotoren (mit zwei Geschwindigkeiten für den TC120d und TC130d).

Lenkung durch Raupendrehung.

Fahrbewegungen servogesteuert, Handbremse-Hebel für TC-120d und TC130d.

Selbstladeschaufel für Schüttmulde,

höchste Kapazität 65 l.

(Option nicht verfügbar für den TC130d).

Zusatzhydraulik (P.T.O.)

mit Doppelwirkung (Optional):

- max 25 l/min, Druck 255 bar für den TC100, TC100d und TC120d

- max 21 l/min, Druck 210 bar für den TC130d

Weitere Durchflüsse und Drücke auf Anfrage verfügbar.

Raupentransporter für verschiedene Zwecke anwendbar.



technical data technische daten

		MT - MTP			CA			BT				AVP			C
		TC100	TC100d	TC120d	TC100	TC100d	TC120d	TC100	TC100d	TC120d	TC130d	TC100	TC100d	TC120d	TC130d
Operational weight (without operator) Einsatzgewicht (ohne Fahrer)	kg	630	630	725	540	540	610	670	670	795	1100	770	770	885	990
Skip capacity Muldeninhalt															
- heaped (SAE standard) gehäuft (SAE standard)	m ³	0,38	0,38	0,44	0,3	0,3	0,3	0,45	0,45	0,45	0,57	0,43	0,43	0,43	0,56
- struck (SAE standard) flach (SAE standard)	m ³	0,32	0,32	0,34	0,21	0,21	0,21	0,36	0,36	0,36	0,46	0,37	0,37	0,37	0,44
- liquids Flüssigkeit	m ³	0,2	0,2	0,21	0,21	0,21	0,21	0,25	0,25	0,25	0,32	0,24	0,24	0,24	0,44

		TC100 - TC100d			TC120d		TC130d
Max payload undercarriage Max Nutzlast Unterwagen	kg	1000			1200		1300
Diesel Engine Dieselmotor	type typ	Kubota Z482			Kubota D722		Kubota D902
Displacement Hubraum	cm ²	479			719		898
Cylinder Zylinder	n°	2			3		3
Max. Power Max. Leistung	kW/Hp	9.6/13 @ 3600 rpm			13.2 /18 @ 3600 rpm		15 /20 @ 2600 rpm
Cooling Kühlung	type typ	Water Wasser			Water Wasser		Water Wasser
Petrol engine Benzinmotor	type typ	Briggs&Stratton Vanguard V-Twin					
Displacement Hubraum	cm ²	450					
Cylinder Zylinder	n°	2					
Max. Power Max. Leistung	kW/Hp	12/16					
Cooling Kühlung	type typ	Air Luft					
Battery Batterie	type typ	12V - 55 Ah			12V - 55Ah		12V - 55Ah
Variable displacement piston pumps for driving Fahrhydraulik: Zwei variable Kolbenpumpen		2x29 lt/min @ 250 bar			2x30 lt/min @ 250 bar		2x33 lt/min @ 250 bar
Gear pump for services Arbeitshydraulik: Zahnradpumpe		1x21 lt/min @ 160 bar			1x21 lt/min @ 160 bar		1x21 lt/min @ 210 bar
Track width Breite der Raupenketten	mm	180			180		230
Track tensioning Kettenspannung	type typ	Spring and screw Feder und Schraube			Spring and screw Feder und Schraube		Spring and screw Feder und Schraube
Specific ground pressure: empty/loaded Bodendruck: im Leerzustand/baladen	kg/cm ²	0.18/0.48			0.18/0.52		0.21/0.42
Max speed Max Geschwindigkeit	km/h	4.0			3.5/4.0		4.0
Max.gradient capability with operational loading Max. befahrbare Steigung mit Betriebslast	%	62			62		60
Fuel tank capacity Kraftstofftank	lt	9.7			9.7		15.2
Hydraulic oil tank capacity Hydrauliköltank	lt	22.1			25.4		26

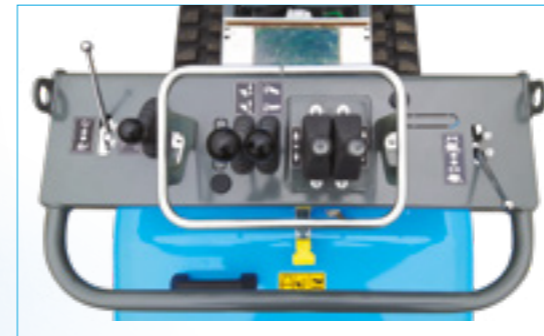

overall dimensions in mm abmessungen mm

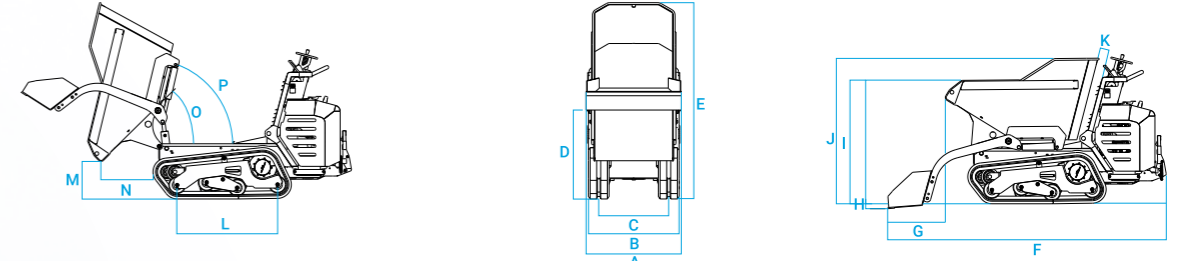

TC100_TC120 MT - MTP	mm	A	B	C	D	E	F	G	H	I	J	K	L	M	N	O	P
TC100	mm	830	790	610	862	1667	1880	504	26	1000	1186	77	875	359	410	45°	76°
TC100d	mm	830	790	610	862	1667	1880	504	26	1000	1186	77	875	359	410	45°	76°
TC120d	mm	830	790	610	775	1710	1924	503	43	1080	1268	78	875	328	452	45°	76°

TC100_TC120 AVP

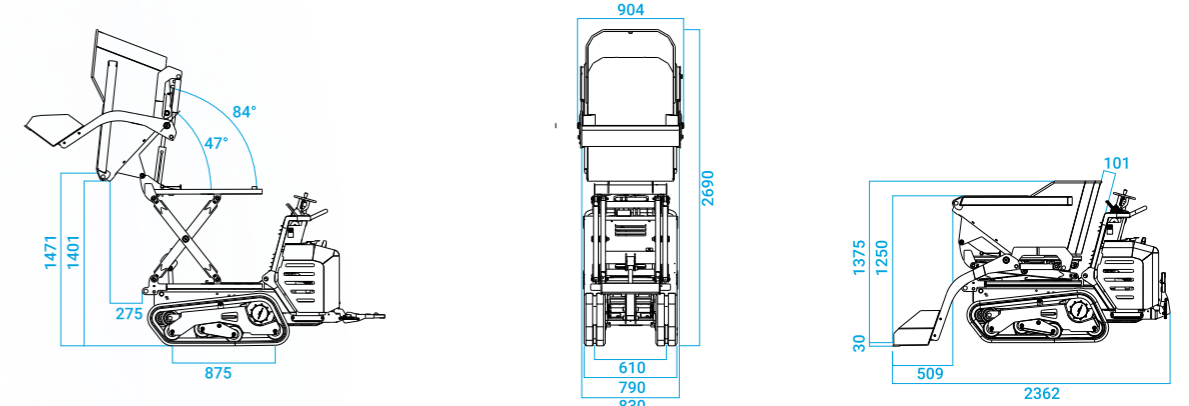

TC100_TC120 CA

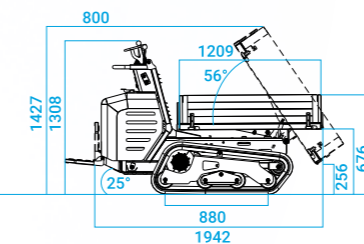

TC100_TC120 BT

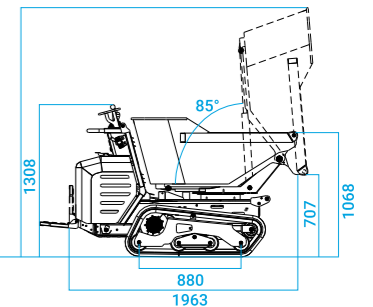
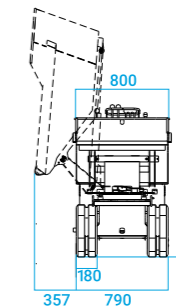

TC130d C

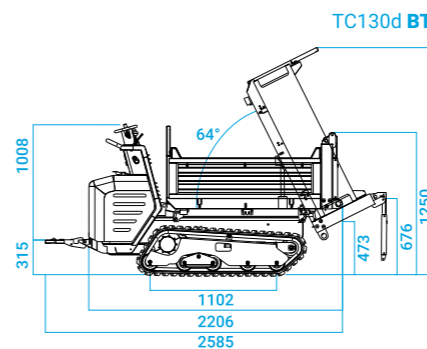
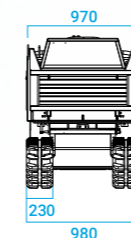

TC130d BT

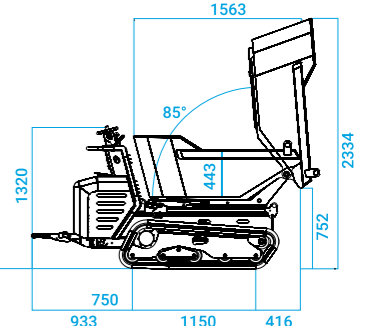
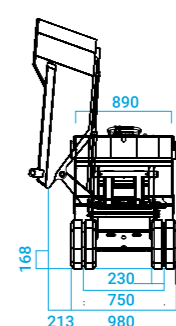

Data, features and pictures are not binding and may be altered without any prior notice. Änderungen ohne Ankündigung vorbehalten, Angaben ohne Gewähr.